

Rubber Suspension Blade Scraper LC1-3S2 Type

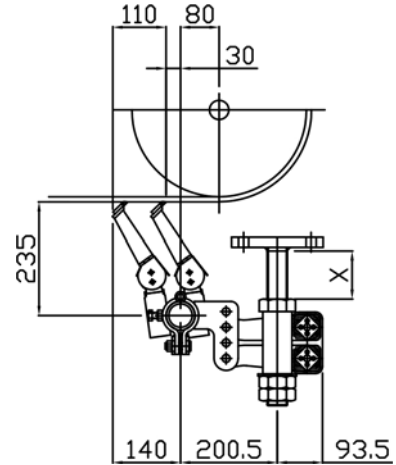
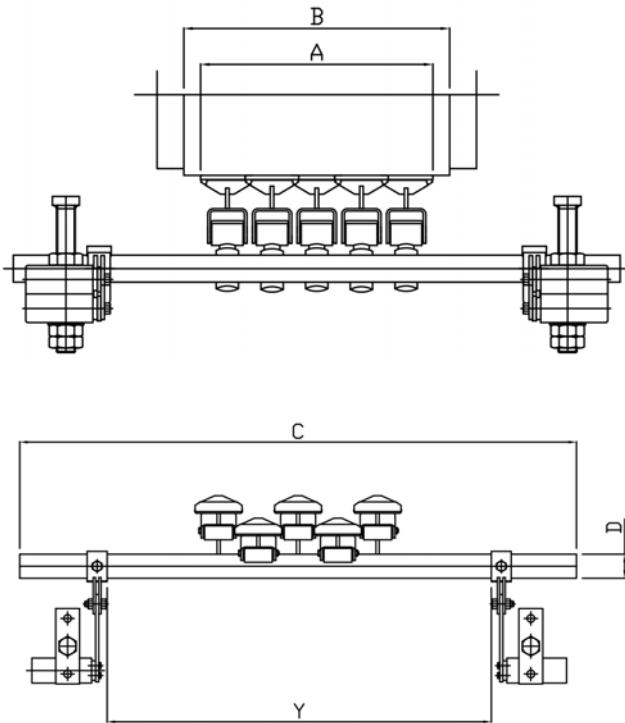

"X" = the tensile axis, the length must be at least 90 mm.

"Y" = the distance between both pressure device should be as short as possible.

Model	Belt size	Tip Size	Module	Body size	D
	A[mm]	B[mm]	Q'ty	C[mm]	
LC1-3S2	600	520	5	1400	∅60,5
	750	620	6	1500	
	800	620	6	1600	
	900	720	7	1700	
	1000	820	8	1800	
	1200	1020	10	2000	
	1400	1220	12	2200	

Without applying pressure above drawing shows the scraper.

During installation, the installation manual is required.



C,P-TYPE BELT CLEANER- Installation Manual

Product Specifications

1. CP Cleaner Body a high-pressure the pipe (STPG) on the molten-plated one